

TORQUE WRENCHES

for “NO NOISE” nut



Why should I use a torque wrench?

While setting a tool it is extremely important to tighten it appropriately. If not effectively tight indeed a cutting tool could slide away from the tool holder during the working process. On the other side, an excessive tightening can cause damages to the tool holder or spring collet or the tool itself.



How to use

Turn the handle to choose the correct torque power based on the router bits diameter. While tightening with constant action a strong shot is perceived both mechanically and acoustically. This indicates that the tightening torque is reached.

Item	D	L	Nm (Ft/lb) (draw. 1)	Nm (Ft/lb) (draw. 2)	Nut
Z052.790.N	32	400	25-35 (18-25)	45-55 (33-40)	ER16
Z052.793.N	50	400	66-70 (48-51)	120-130 (88-95)	ER32
Z052.795.N	60	400	110-120 (81-88)	190-200 (140-147)	EOC25-DIN 6388

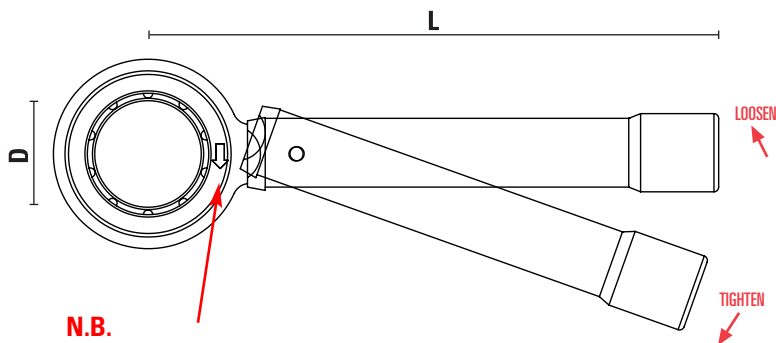

**N.B.
THE REFERENCE ARROW SHOULD BE
VISIBLE FROM THE FRONT**

WEBSITE

