

# TORQUE WRENCHES for “MINI” nut



## Why should I use a torque wrench?

While setting a tool it is extremely important to tighten it appropriately. If not effectively tight indeed a cutting tool could slide away from the tool holder during the working process. On the other side, an excessive tightening can cause damages to the tool holder or spring collet or the tool itself.



### How to use

While tightening with constant action a strong shot is perceived both mechanically and acoustically. This indicates that the tightening torque is reached.

Item	D	L	Nm (Ft/lb)	Nut
Z052.701.N	16	120	18 (13)	ER11
Z052.702.N	22	175	28 (21)	ER16
Z052.703.N	28	180	35 (25)	ER20
Z052.704.N	35	185	40 (29)	ER25

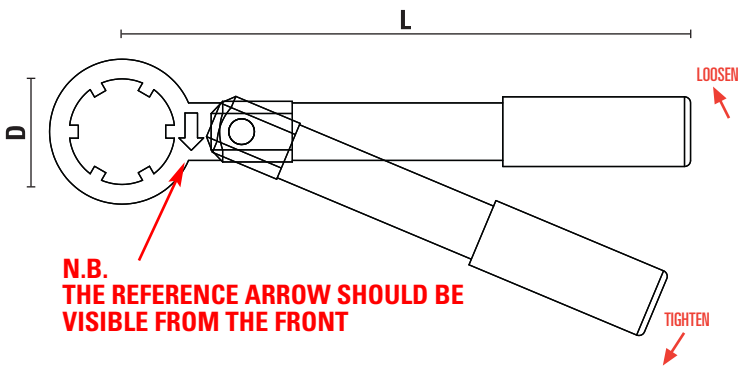

WEBSITE

